

RANCH HAND PATTERN

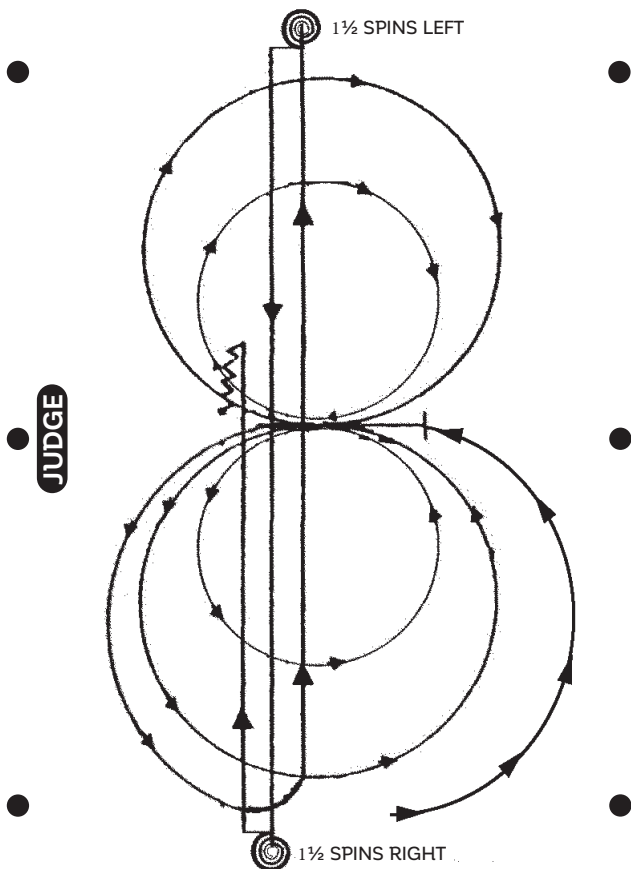

Begin on left lead. At the center, without stopping or breaking gait, begin pattern toward the judge. Refer to rule 20.6.

1. Beginning on the left lead complete 2 circles to the left, the first circle large and fast, and the second circle small and slow. STOP at center.
2. Depart on right lead, 2 circles to the right, the first large and fast, the second small and slow. STOP at center.
3. Depart on left lead, continue around end of arena without breaking gait or changing leads, run down center of the arena past the end marked, execute a square sliding stop.
4. Complete 1 1/2 spins to the left.
5. Run down center of arena past end marker, execute a square sliding stop.
6. Complete 1 1/2 spins to the right.
7. Run down center of arena past center marker, execute a square sliding stop. Back at least 10 feet. Hesitate to complete pattern.