

## RANCH HAND / BUCKAROO

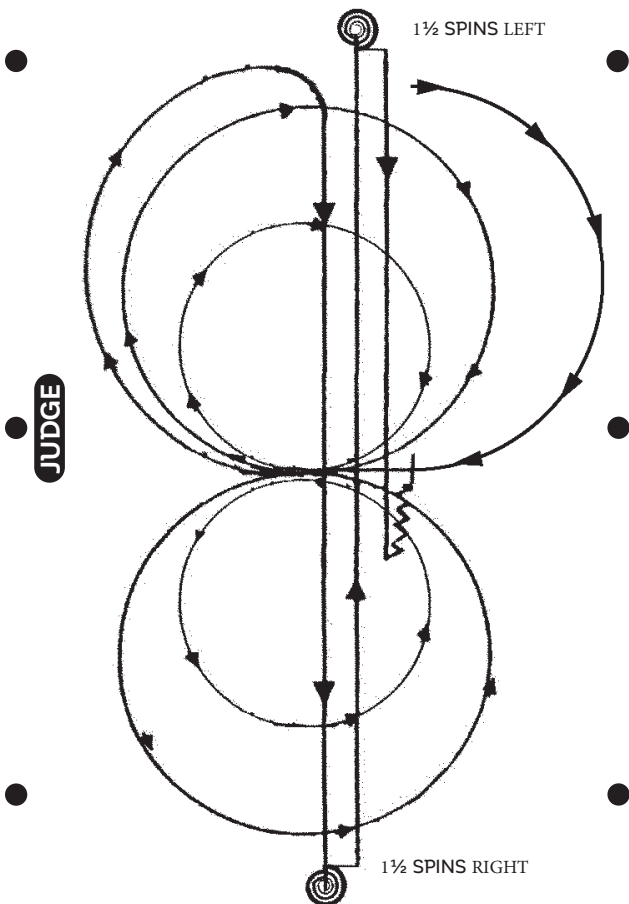

Begin on right lead. At the center, without stopping or breaking gait, begin pattern facing toward the judge. Refer to rule 20.6.

1. Beginning on the right lead complete 2 circles to the right, the first circle large and fast, and the second circle small and slow. Stop at the center of the arena.
2. Depart on the left lead and complete 2 circles to the left, the first circle large and fast, and the second circle small and slow. Stop at the center of the arena
3. Depart on right lead, continue around end of arena without breaking gait or changing leads, run down center of the arena past the end marker, execute a square sliding stop.
4. Complete 1½ spins to the right.
5. Run down center of arena past end marker, execute a square sliding stop.
6. Complete 1½ spins to the left.
7. Run down center of arena past center marker, execute a square sliding stop. Back at least 10 feet. Hesitate to complete pattern.